

**IANBENNIE AND ASSOCIATES**

**TEST REPORT NO. 6026-S2-NZ-2014**

**ZENDOW UPVC FRENCH INWARD  
CASEMENT WITH TILT-TURN WINDOW  
PROTOTYPE TEST to NZS 4211-2008**

**for**

**DECEUNINCK**

**March 2019**



Accreditation No. 2371

Accredited for compliance with ISO/IEC 17025 - Testing



# IAN BENNIE & ASSOCIATES PTY. LTD.

## Building Performance Testing

ACN : 007 133 253

### TEST REPORT NUMBER 6026-S2-NZ-2014

CAVEAT: THIS REPORT IS BASED ON THE PREMISE THAT NO DETAILING OR MATERIAL HAS CHANGED SINCE THE ORIGINAL 2006 TEST - NO LIABILITY FOR ANY SUBSEQUENT CHANGES IS APPLICABLE

**Test Client:** DECEUNINCK

#### Sample

**Identification:** A Zendow UPVC French Inward Casement with Tilt-Turn Window, measuring 1500 mm in height x 1500 mm in width. The sample is detailed in the DECEUNINCK drawings given in Appendix B .

**Test Method:** Tests were conducted and performance was assessed in accordance with the Serviceability Deflection, Air Infiltration, Water Penetration and Ultimate Strength procedures of New Zealand Standard NZS4211:2008, as detailed in Appendix A

Torsional tests and Operating Resistance force tests were not requested by the Client.

Note: The tests to this New Zealand Standard were conducted in conjunction with tests to Australian Standard AS2047.

**Test Location:** IBA Test Centre                      **Test Date(s):** 5 & 18 April 2006.  
Dandenong, Melbourne.

**Pre-loading:** The sample was operated five (5) times prior to the commencement of testing.

## TEST RESULTS

### Serviceability Deflection Test

Deflections recorded:

	<b>Requirement span/200</b>	
Pressure (Pa)	<b>+2310</b>	<b>-2310</b>
<b>MULLION</b>		
Deflection	Span/256	Span/245
<b>SASH BOTTOM RAIL</b>		
Deflection	Span/1487	Span/6936

All test readings and calculated deflections are given in Table 1 and measurement locations are indicated on Figure 1.

### Air Infiltration Test

<b>Air Leakage Recorded</b> (L / s.m <sup>2</sup> )	<b>Pressure Applied (Pa)</b>	
	<b>+151</b>	<b>-153</b>
<b>Condition</b>		
Chamber & Sample (A):	0.44	-0.30
Chamber (sample taped) (B):	NR	NR
<b>Sample (A-B):</b>	<b>0.44</b>	<b>-0.30</b>

<b>Sash joint length: 8.64 m</b>		
<b>Air Leakage Recorded</b> (L / s.m of joint)	<b>0.11</b>	<b>-0.08</b>

NR: measurement not required

### Water Leakage Test 250 Pa

No water was observed during the test.

### Water Leakage Test 300 Pa

Water penetrated past the sill airseal of the RH sash during the test, which constitutes a failure.

### Ultimate Strength Test: ±2310 Pa

No sign of collapse was observed at either test pressure.

**CONCLUSION**

The Zendow UPVC French Inward Casement with Tilt-Turn Window sample achieved the following ratings per NZS4211:2008 Amd 1 for Serviceability Deflection, Air Infiltration, Water Penetration and Ultimate Strength.\*

**For buildings not requiring specific design**

Window Rating (SLS) ....MEDIUM Wind Zone‡  
Window Rating (ULS) ...EXTRA HIGH Wind Zone  
Air Leakage ..... Air conditioned

**For buildings requiring specific design**

Window rating for SLS .....+830‡ and -2310 Pa  
Window rating for ULS .....+2310 and -2310 Pa  
Air Leakage .....Air conditioned

‡ limited by water leakage test result

\* Torsional tests and Operating Resistance force tests were not requested by the Client.



***This report shall not be reproduced except in full.***

**DISTRIBUTION:**

Ian Bennie & Associates ..... 3  
DECEUNINCK ..... PDF

*Ian Bennie*  
Ian Bennie                      18 March 2019  
Authorised Signatory

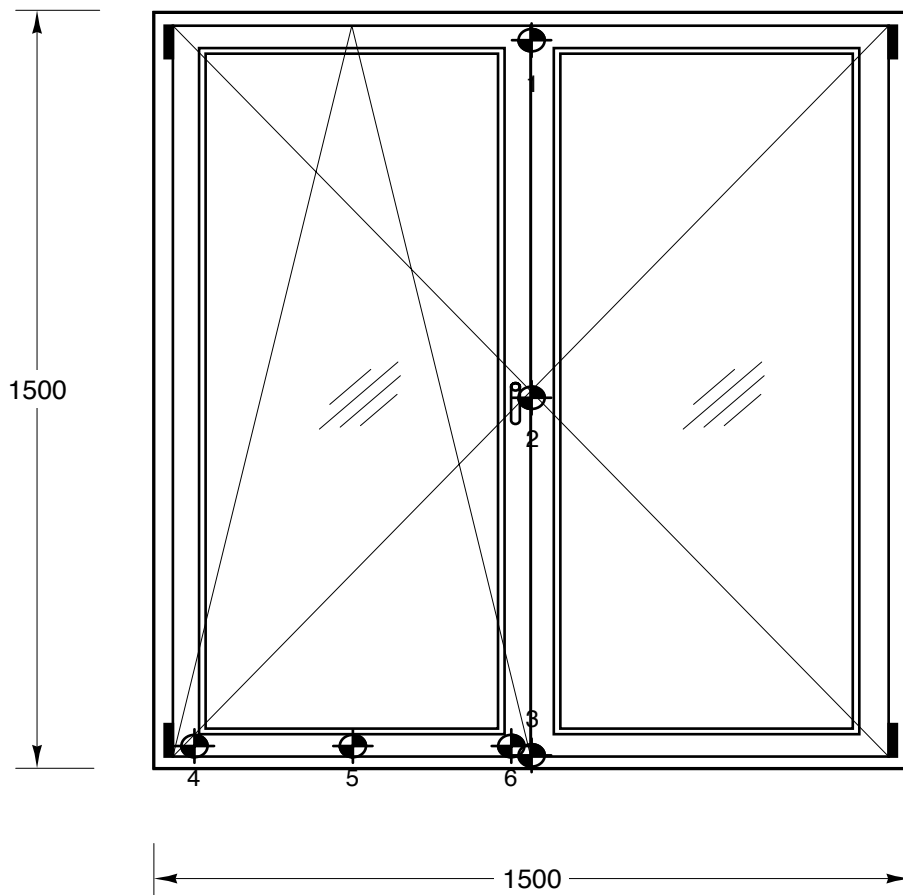

**INDOOR VIEW**

⊙ Displacement measurement locations:

- 1. Mullion - top
- 2. Mullion - centre
- 3. Mullion - bottom
- 4. Door Rail - left
- 5. Door Rail - centre
- 6. Door Rail - right

Figure 1. Indoor view of the test sample showing the displacement measurement locations.

**Table 1**

**STRUCTURAL PERFORMANCE**

DATAFILE 526		TEST NUMBER 1			DATE : 05/04/2006		
MEMBER	PRESSURE  (kPa)	DISPLACEMENTS ( rounded to 0.1 mm )			BENDING DEFLECTION ( rounded to 0.01 mm )	SPAN  L (mm)	SDR  L/DEF
		LEFT OR TOP  D1 (mm)	CENTRE  DC (mm)	RIGHT OR BOTTOM  D2 (mm)	DC - $\frac{D1+D2}{2}$  DEF (mm)		
1,2,3	MULLION						
	0.50	0.5	2.0	1.1	1.17	1366	1166
	0.70	0.7	2.8	1.5	1.67		818
	1.00	1.3	4.1	2.2	2.33		586
	1.52	2.6	6.6	3.5	3.54		386
	2.00	4.5	9.3	4.9	4.63		295
	2.31	6.1	11.3	5.9	5.33		256
	-0.00	0.7	0.7	0.6	0.11		11878
	-0.51	-0.8	-2.0	-1.1	-1.06		-1288
	-1.00	-1.5	-3.9	-1.9	-2.23		-612
	-1.51	-2.3	-6.1	-2.6	-3.58		-382
	-2.00	-3.1	-8.1	-3.5	-4.79		-285
	-2.22	-3.6	-9.2	-4.0	-5.37		-254
	-2.31	-3.7	-9.5	-4.1	-5.57		-245
-0.00	-0.4	-0.7	-0.6	-0.11	-12495		
4,5,6	BOTTOM SASH RAIL						
	0.50	1.2	0.8	0.3	0.03	630	18996
	0.70	1.6	1.1	0.5	0.10		6094
	1.00	2.2	1.7	0.8	0.14		4416
	1.52	3.5	2.7	1.4	0.27		2370
	2.00	4.9	3.9	2.1	0.35		1805
	2.31	5.9	4.7	2.6	0.42		1487
	-0.00	0.7	0.5	0.3	-0.02		-25772
	-0.51	-1.1	-0.6	-0.2	0.06		9922
	-1.00	-1.9	-1.1	-0.4	0.06		10139
	-1.51	-2.6	-1.6	-0.6	0.03		19084
	-2.00	-3.5	-2.2	-0.9	-0.05		-13917
	-2.22	-4.0	-2.6	-1.0	-0.07		-9396
	-2.31	-4.1	-2.7	-1.1	-0.09		-6936
-0.00	-0.7	-0.4	-0.2	0.04	17118		

# APPENDIX A - Test Procedures for NZS 4211:2008 - Amd 1

## 1Preparation for Tests - AS4420.1-1996

### Test Description

Prior to commencement of the main tests listed below, any operable windows or doors are to be opened and close five (5) times. The sample is to be subject to positive or negative wind pressures being 50% of the nominated deflection test pressures. This is a pre-requirement for each of the main tests. However, when more than one of the tests is to be conducted the preparations need only be conducted once.

## 2Serviceability Deflection Test - AS4420.2-1996

### Test Description

Measurements of movement of critical structural members are taken at a range of test pressures in order to determine if the bending of the members exceed the nominated requirements.

### NZ Test Parameters

**Test Pressure:** is dependent on the Window Rating –

Window Rating	Test Pressure (Pa)
Low	±510
Medium	±680
High	±970
Very High	±1250
Extra High	±1515

**Test pressure steps:** as given below

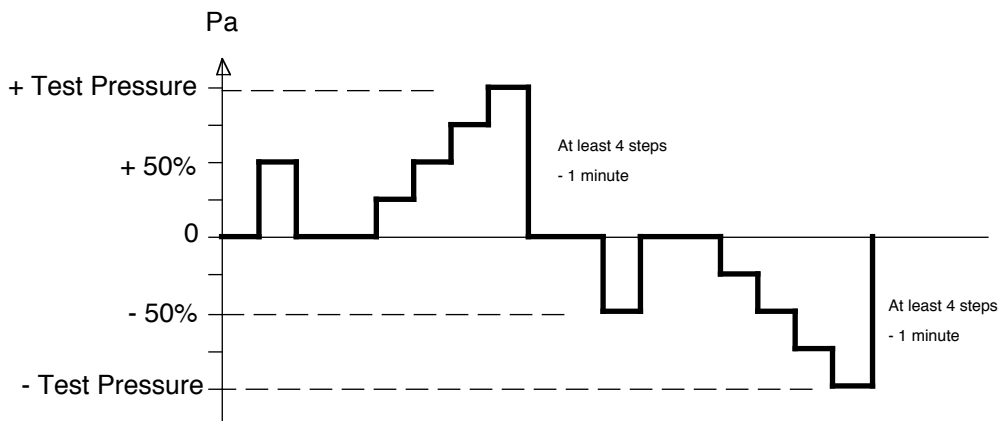

**Pass / Fail criteria:**

Maximum deflection for structural members: 1/200 of span.

## 3Operating Force Test : AS4420.3-1996

### Test Description

The forces required to operate sliding doors and windows are measured to test compliance with the requirements.

### NZ Test Parameters

**Test measurements:** The forces required to initiate and sustain movement of the door/sash in both directions of movement are recorded.

**Pass / Fail criteria :** Forces shall not exceed the following

Force (Newtons)	Projecting sashes	Sliding window type		Sliding doors
		Horizontal	Vertical	
To initiate movement	90	110	200	180
To sustain movement	90	90	160	110

#### 4Operation Resistance Test - per Section 7.1 and 7.2 of NZS 4211

##### Test Description

Small forces are applied to operable sashes to determine if they move too freely.

##### Test Parameters

**Test loads:** Vertical Sliding Sashes: 10 N upward and downward.  
Projecting Sashes: Force = (35 x Area of Sash in m<sup>2</sup>) N, inward and outward at all angles of opening.

**Pass / Fail criteria :** The position of the sash shall not change when subjected to the force.

#### 5Air Infiltration Test - AS4420.4-1996

##### Test Description

Air leakage through the entire test sample is measured at the nominated pressures in order to determine if it exceeds the allowable rate.

##### NZ Test Parameters

**Pass / Fail criteria :** Maximum air infiltration shall not exceed the following:  
**Fixed Windows:** Value shown on the table for “Per m<sup>2</sup> of Sample”.  
**Windows Containing Sashes:** Value is the geometric mean of the respective calculated infiltration rates for both the “Per m<sup>2</sup> of Sample” and “Per m of opening joint length” in the table.

Rate of air infiltration	Litres per second (L/s)	
	Air conditioned	Non air conditioned
Per m <sup>2</sup> of Sample	1.6	8.0
Per m of opening joint length	0.6	2.0

#### 6Water Penetration Resistance Test - AS4420.5-1996

##### Test Description

Water is sprayed onto the outdoor face of the test sample with air pressure simultaneously being applied across it to determine if unacceptable water leakage occurs.

##### NZ Test Parameters

**Test pressure :** The test pressure is dependent on the rating:

Window Rating	Test Pressure (Pa)
Low	153
Medium	204
High	291
Very High	375
Extra High	455
Specific Design	30% of SLS

**Test duration:** The test pressure shall be maintained for 15 minutes.

**Water application rate :** 0.05 litre per second per square metre of sample area.



**Pass / Fail criteria :**

The window shall be designed to permit no uncontrolled water penetration through the window at a static positive air pressure.

Uncontrolled water penetration is defined as-

- (a) water that is not contained in a purpose-built drainage area;
- (b) water that may wet window fixtures and finishes, reveal linings or window furnishings beyond the window frame; or
- (c) water that flows in a constant stream on the inside, or dripping.

Acceptable water penetration is defined as-

- (a) minor splashing which occurs due to air infiltration, within 1 mm after change of pressure;
- (b) minor, intermittent leakage on the indoor side of operable sashes, which is contained on gaskets, sill tracks and thresholds.

A purpose built collection or drainage area is defined as a system that allows water to collect or be drained to the outside (at the cessation of testing) from sills, other framing members or cavities.

**7Ultimate Strength Test - AS4420.6-1996**

**Test Description**

Air pressure greater than the design pressure is applied across the test sample in order to demonstrate that it has a suitable structural safety margin.

**NZ Test Parameters**

**Test Pressure:** is dependent on the Window Rating -

Window Rating	Test Pressure (Pa)
Low	±720
Medium	±960
High	±1360
Very High	±1760
Extra High	±2130
Extreme	±2500

**Pass / Fail criteria:**

Windows shall not collapse when subjected to the test pressures for a period of ten (10) seconds. Collapse is defined as any one, or any combination, of the following:

- (a) Dislodgement or breaking of any glazing.
- (b) Dislodgment of a frame or any part of a frame.
- (c) Dislodgement of a sash from its frame.
- (d) Loss of support of a frame, such as when it is unstable in its opening in the building structure.
- (e) Failure of any sash, locking device, fastener or supporting stay allowing an opening light to open.

**8Torsional Strength of Sashes - per Appendix A of NZS 4211**

**Test Description**

Projecting sashes are tested with a torsional load to provide an indication of the likely smoothness of operation.

**Test Parameters**

**Test Load:** a load of 45 N is applied at one corner of the sash in both directions, perpendicular to the plane of the sash, while the other three corners of the sash are held in plane.

**Pass / Fail criteria:**

The deflection at the corner of the sash shall not exceed 0.04 times the length of the shortest of the two members joined at the point of the load, or 50 mm whichever is the lesser.

## **Appendix B – Client drawings**

Sample elevation  
Drainage details  
Hardware accessory drawing  
Main profiles  
Glazing beads

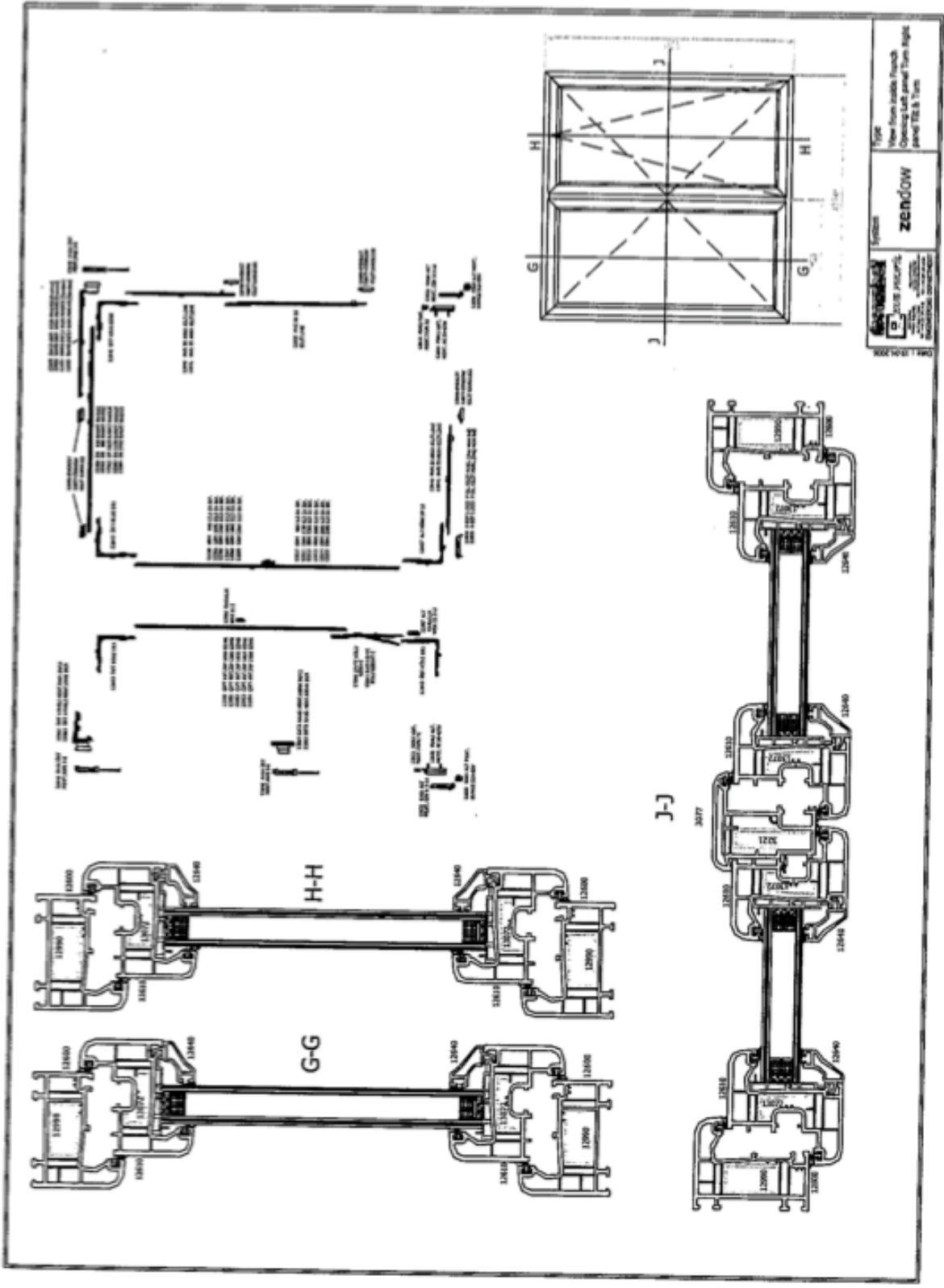

## FRENCH OPENING

Gaskets : TPE (Thermo Plastic Elastomer)  
Sealant used on outdoor gaskets.

Drain Holes – Frame : three on left panel  
                                    Three on right panel  
                                    Sash : three on left panel  
                                    Three on right panel

A cap used outlet of each drain holes (part number 12084)

Air Slots – 5 mm diameter : two each pair of frame and sash

Glazing 4 mm Clear Float; 4-12-4 double glazing units used

The fasteners used to fix, each steel reinforcement should be no less than 3, with a gap around 300 mm.

main profiles

zendow.

12600

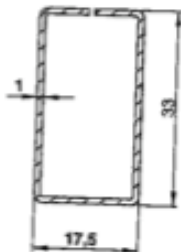
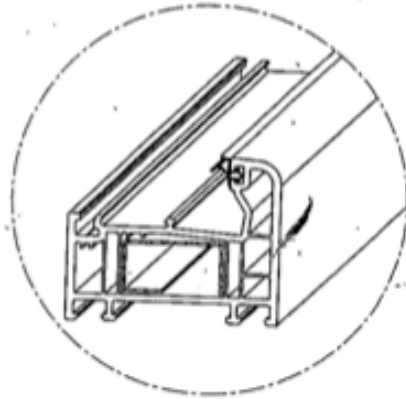
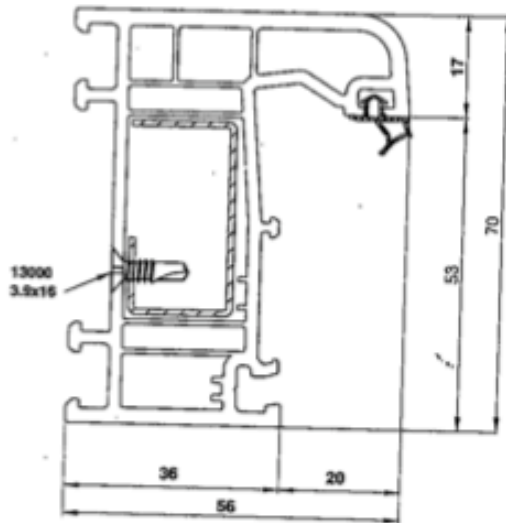

Y ↑ **12990**  
Ix : 1.3215 cm<sup>4</sup>  
Iy : 0.4993 cm<sup>4</sup>  
X →

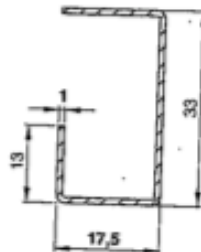

Y ↑ **12991**  
Ix : 1.2182 cm<sup>4</sup>  
Iy : 0.3424 cm<sup>4</sup>  
X →

main profiles

zendow.

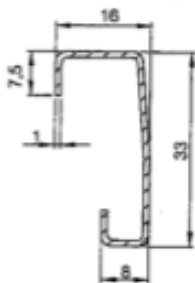
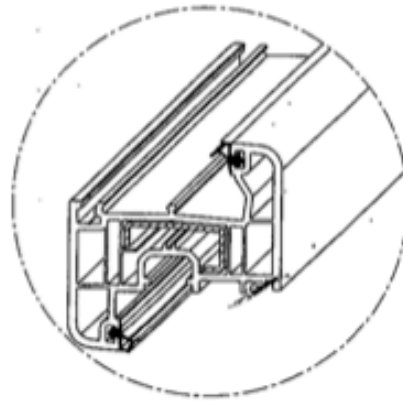
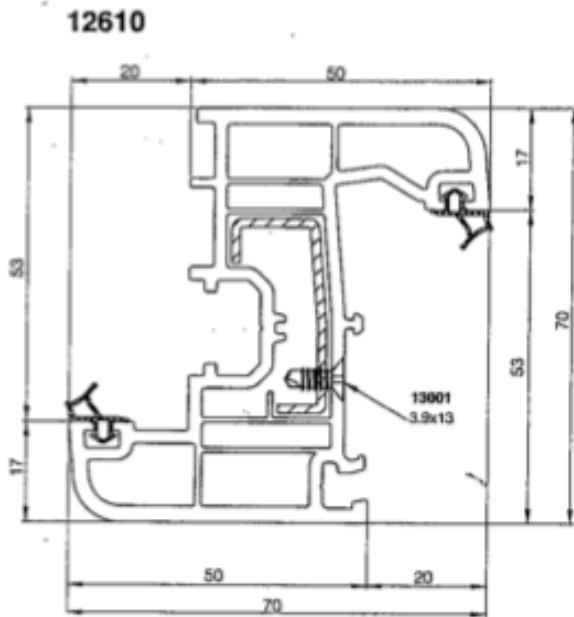

**13070**  
 $I_x : 0.9434 \text{ cm}^4$   
 $I_y : 0.1723 \text{ cm}^4$

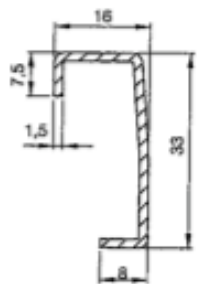

**13071**  
 $I_x : 1.1892 \text{ cm}^4$   
 $I_y : 0.2315 \text{ cm}^4$

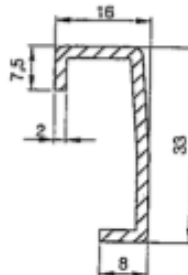

**13072**  
 $I_x : 1.5088 \text{ cm}^4$   
 $I_y : 0.2632 \text{ cm}^4$

main profiles

zendow.

3077

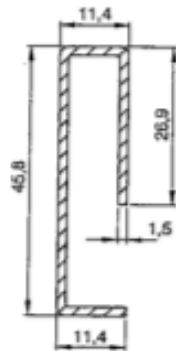
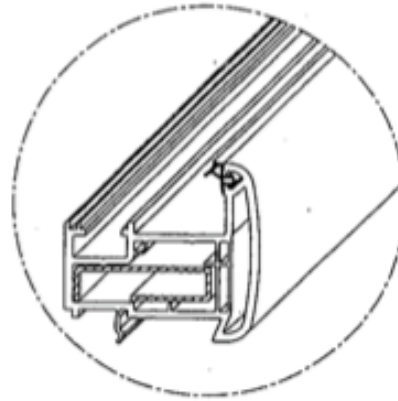
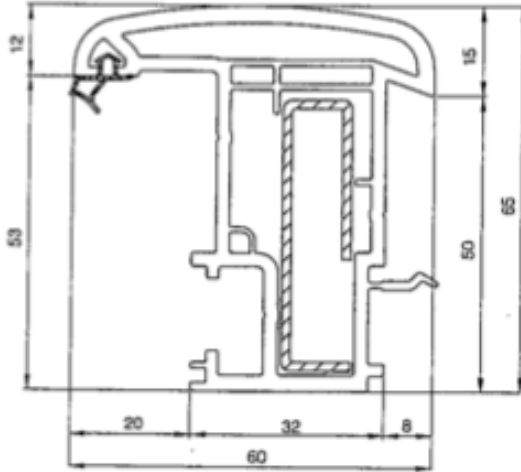

Y  
**3221**  
Ix : 3.0088 cm<sup>4</sup>  
Iy : 0.2738 cm<sup>4</sup>  
X

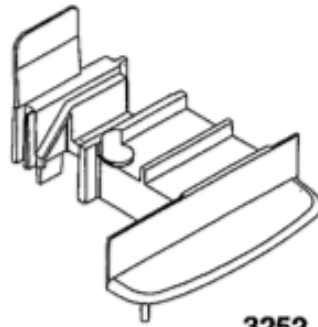

3252  
→ 3077

glazing beads

zendow.

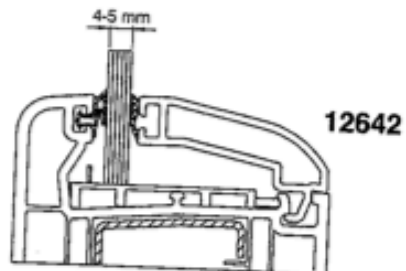
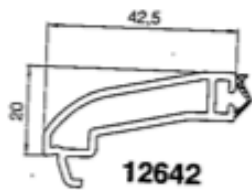
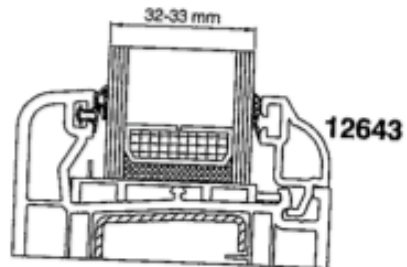
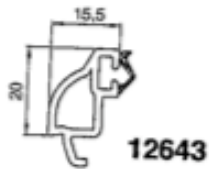
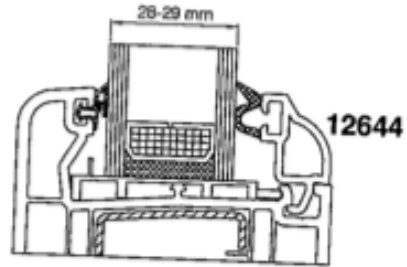
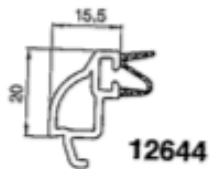
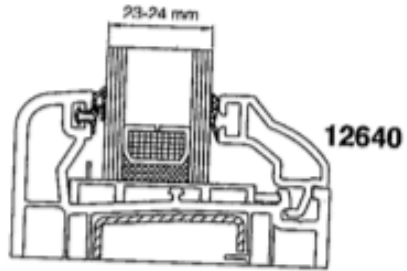
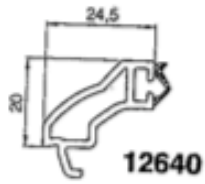
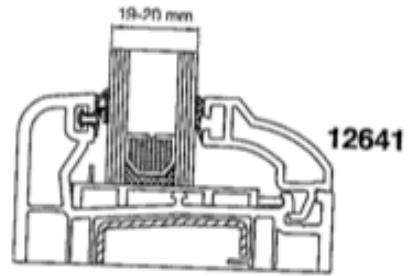
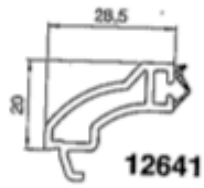



french opening  
hardware of french opening tilt & turn

zendow.

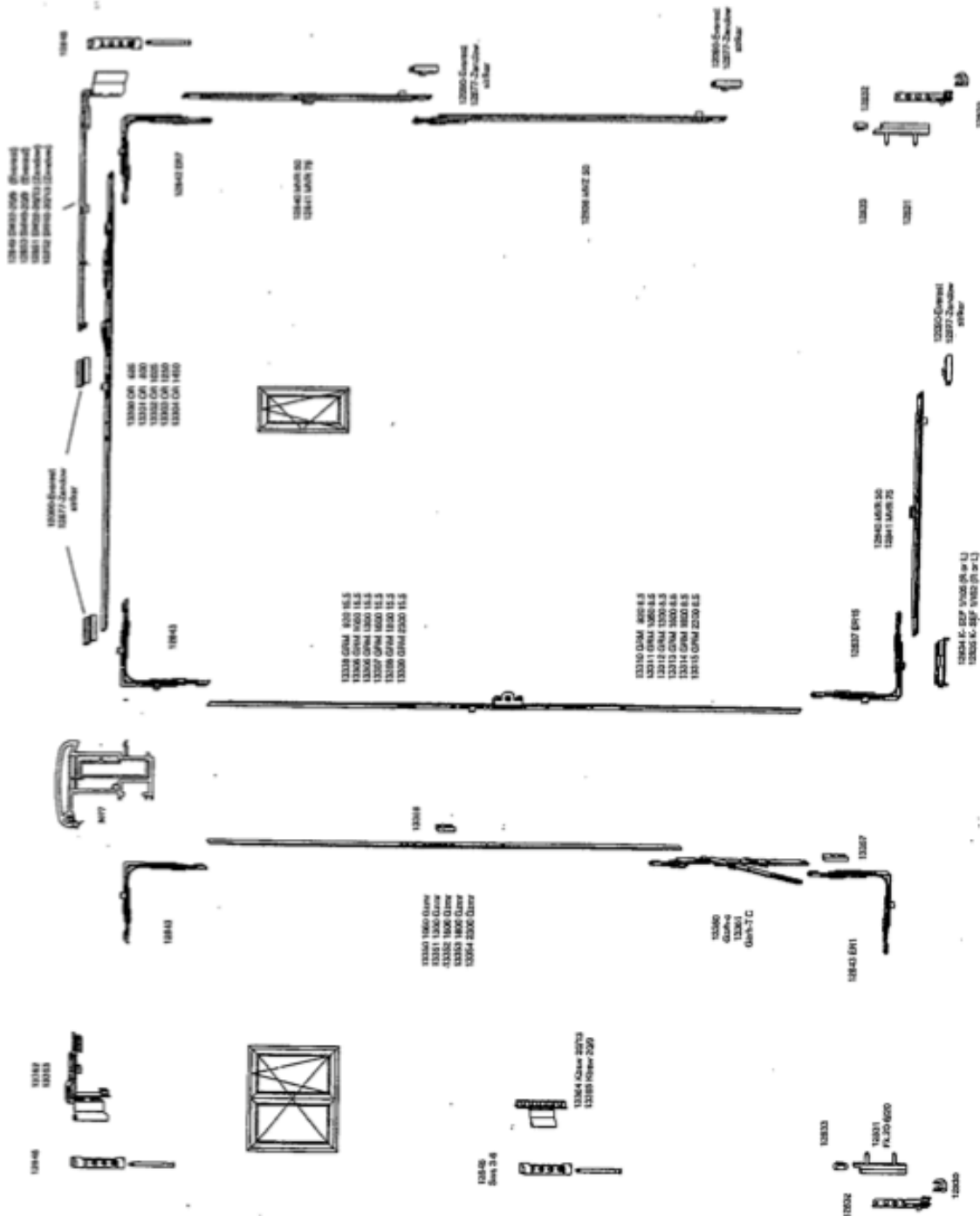

drainage  
frame

zendow.

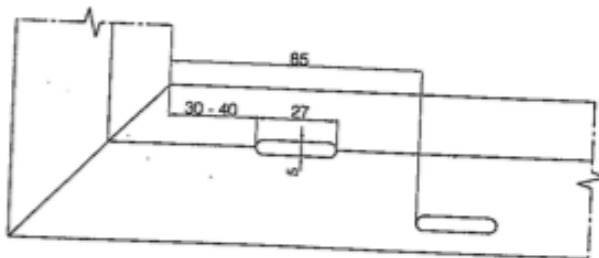
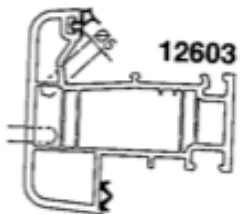
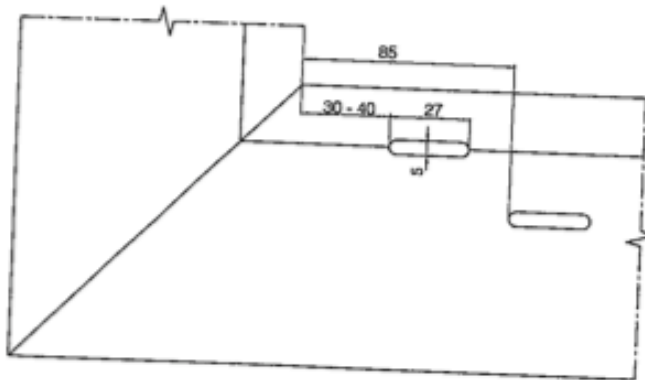
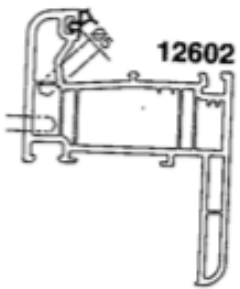
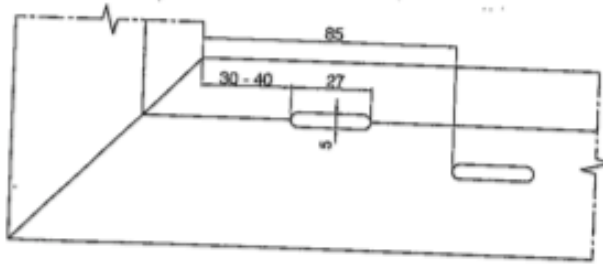
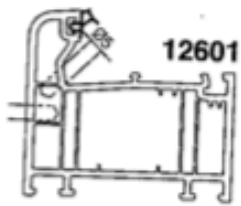
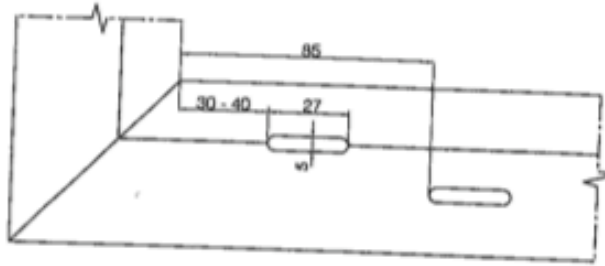
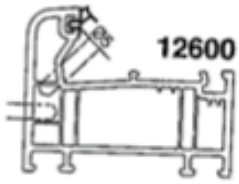

drainage  
sash profile

zendow.

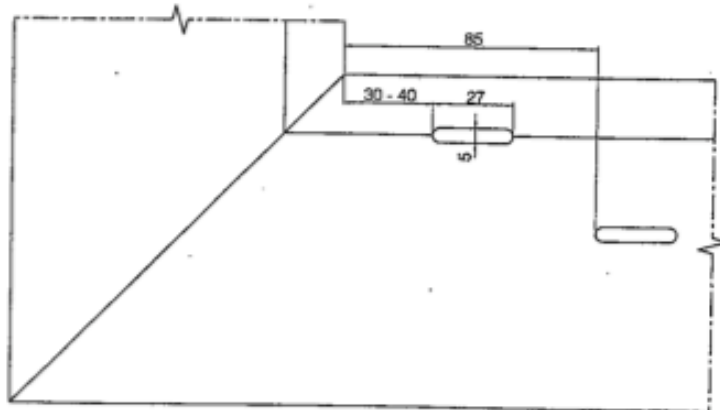
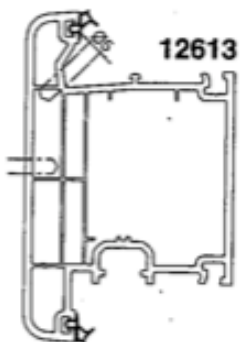
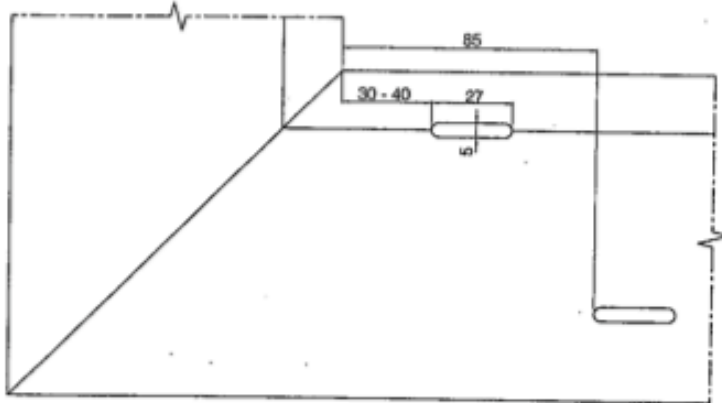
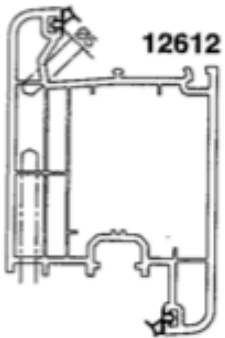
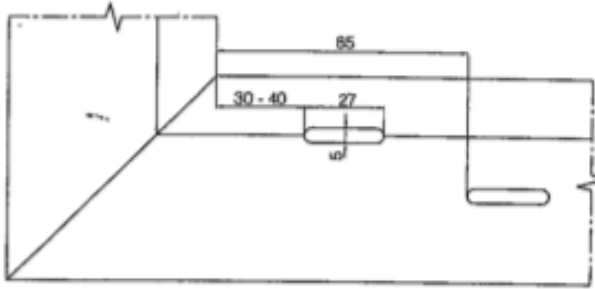
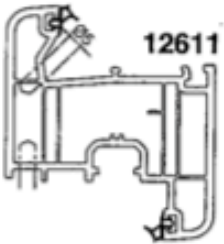
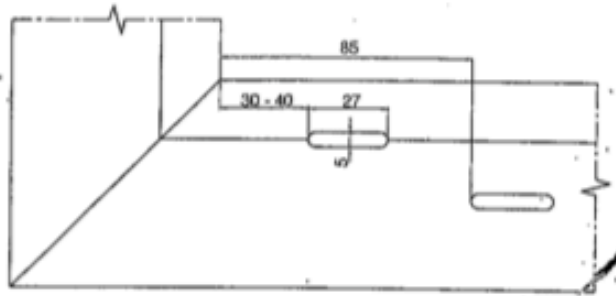
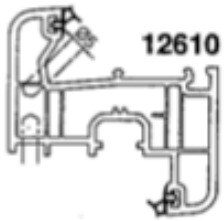

View from inside

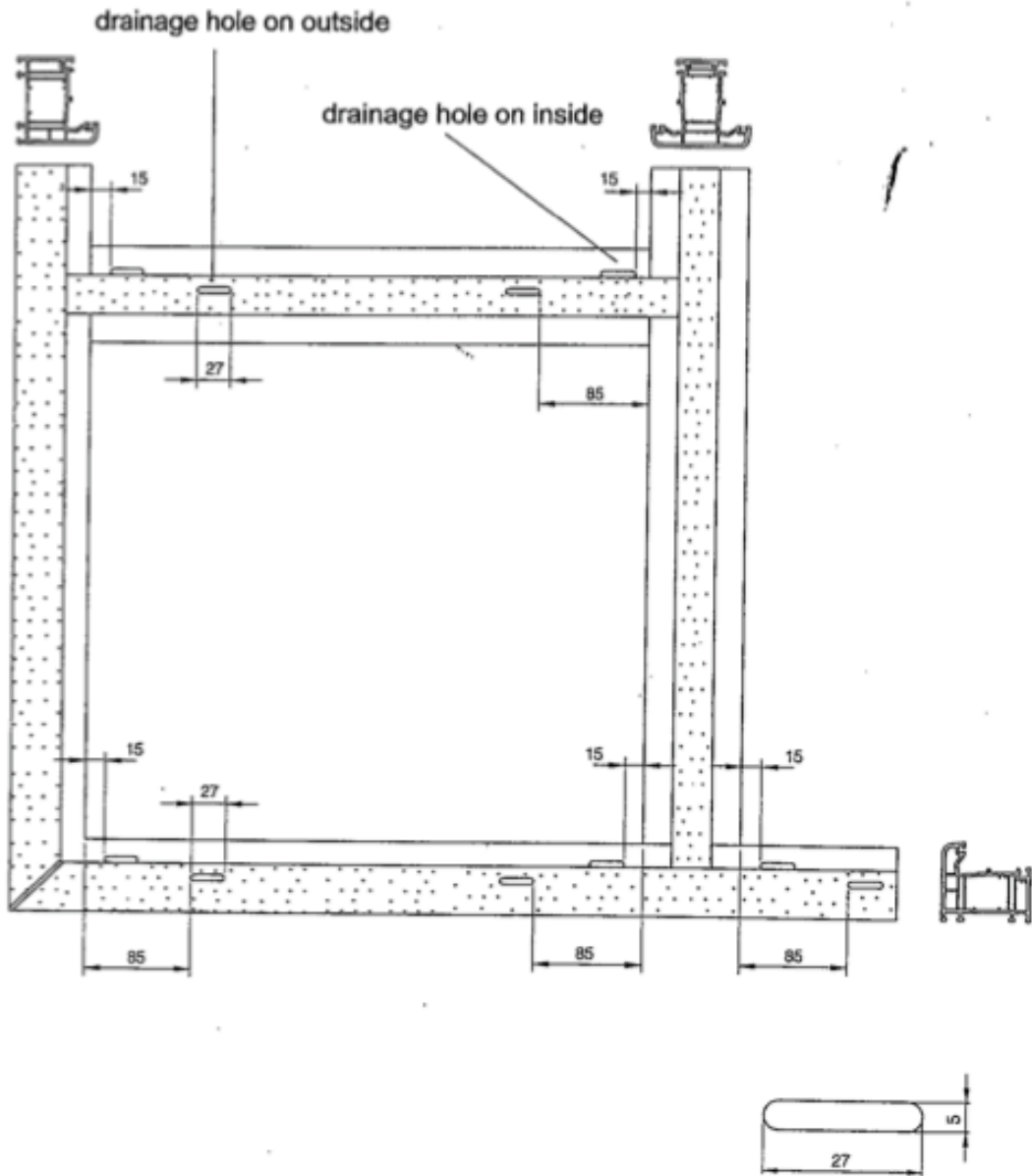

**drainage**  
**water discharge and air slots**

**zendow.**

